

Botany

Secti on-A

Plant Kingdom

- Which of the following is **incorrectly** matched?
 - Volvox* - Starch
 - Ectocarpus* - Fucoxanthin
 - Ulothrix* - Mannitol
 - Porphyra* - Floridean Starch
- Hydrocolloid carrageen is obtained from:
 - Phaeophyceae only
 - Chlorophyceae and Phaeophyceae
 - Phaeophyceae and Rhodophyceae
 - Rhodophyceae only

Morphology of Flowering Plants

- Which one of the following plants shows vexillary aestivation and diadelphous stamens?
 - Solanum nigrum*
 - Colchicum autumnale*
 - Pisum sativum*
 - Allium cepa*
- Identify the **correct set** of statements:
 - The leaflets are modified into pointed hard thorns in *Citrus* and *Bougainvillea*
 - Axillary buds form slender and spirally coiled tendrils in cucumber and pumpkin
 - Stem is flattened and fleshy in *Opuntia* and modified to perform the function of leaves
 - Rhizophora* shows vertically upward growing roots that help to get oxygen for respiration
 - Subaerially growing stems in grasses and strawberry help in vegetative propagation

Choose the correct answer from the options given below.

 - A, B, D and E only
 - B and C only
 - A and D only
 - B, C, D and E only

- The flowers are Zygomorphic in:
 - Mustard
 - Gulmohar
 - Cassia*
 - Datura*
 - Chilli

Choose the **correct answer** from the options given below.

- C, D and E only
- A, B and C only
- B and C only
- D and E only

Anatomy of Flowering Plants

- Read the following statements about the vascular bundles:
 - In roots, xylem and phloem in a vascular bundle are arranged in an alternate manner along the different radii
 - Conjoint closed vascular bundles do not possess cambium
 - In open vascular bundles, cambium is present in between xylem and phloem
 - The vascular bundles of dicotyledonous stem possess endarch protoxylem
 - In monocotyledonous root, usually there are more than six xylem bundles present

Choose the **correct answer** from the options given below.

- A, C, D and E only
 - A, B and D only
 - B, C, D and E only
 - A, B, C and D only
- In old trees the greater part of secondary xylem is dark brown and resistant to insect attack due to
 - Secretion of secondary metabolites and their deposition in the lumen of vessels
 - Deposition of organic compounds like tannins and resins in the central layers of stem
 - Deposition of suberin and aromatic substances in the outer layer of stem
 - Deposition of tannins, gum, resin and aromatic substances in the peripheral layers of stem
 - Presence of parenchyma cells, functionally active xylem elements and essential oils.

Choose the correct answer from the options given below.

- B and D only
- A and B only
- C and D only
- D and E only

Biomolecules

8. Exoskeleton of arthropods is composed of:
- Glucosamine
 - Cutin
 - Cellulose
 - Chitin

Cell Cycle and Cell Division

9. Which one of the following **never** occurs during mitotic cell division?
- Coiling and condensation of the chromatids
 - Spindle fibres attach to kinetochores of chromosomes
 - Movement of centrioles towards opposite poles
 - Pairing of homologous chromosomes
10. The appearance of recombination nodules on homologous chromosomes during meiosis characterizes?
- Terminalization
 - Synaptonemal complex
 - Bivalent
 - Sites at which crossing over occurs

Transport in Plants

11. Which of the following is **not** observed during apoplastic pathway?
- Apoplast is continuous and does not provide any barrier to water movement.
 - Movement of water occurs through intercellular spaces and wall of the cells
 - The movement does not involve crossing of cell membrane
 - The movement is aided by cytoplasmic streaming
12. "Girdling Experiment" was performed by Plant Physiologists to identify the plant tissue through which:
- Osmosis is observed
 - Water is transported
 - Food is transported
 - For both water and food transportation

Mineral Nutrition

13. Which one of the following produces nitrogen fixing nodules on the roots of *Alnus*?
- Beijernickia*
 - Rhizobium*
 - Frankia*
 - Rhodospirillum*
14. Match List-I with List-II.

List-I		List-II	
(A)	Manganese	(i)	Activates the enzyme catalase
(B)	Magnesium	(ii)	Required for pollen germination
(C)	Boron	(iii)	Activates enzymes of respiration
(D)	Iron	(iv)	Functions in splitting of water during photosynthesis

Choose the correct answer from the options given below.

- A-iii B-i C-ii D-iv
- A-iii B-iv C-i D-ii
- A-iv B-iii C-ii D-i
- A-iv B-i C-ii D-iii

Photosynthesis in Higher Plants

15. Given below are two statements:
- Statement I:** The primary CO_2 acceptor in C_4 plants is phosphoenolpyruvate and is found in the mesophyll cells.
- Statement II:** Mesophyll cells of C_4 plants lack RuBisCO enzyme
- In the light of the above statements, choose the correct answer from the options given below.
- Statement I is incorrect but Statement II is correct
 - Both Statement I and Statement II are correct
 - Both statement I and statement II are incorrect
 - Statement I is correct but Statement II is incorrect
16. Which one of the following is **not true** regarding the release of energy during ATP synthesis through chemiosmosis? It involves:
- Reduction of NADP to NADPH_2 on the stroma side of the membrane
 - Breakdown of proton gradient
 - Breakdown of electron gradient
 - Movement of protons across the membrane to the stroma

Respiration in Plants

17. What is the net gain of ATP when each molecule of glucose is converted to two molecules of pyruvic acid?
- Eight
 - Four
 - Six
 - Two
18. What amount of energy is released from glucose during lactic acid fermentation?
- Less than 7%
 - Approximately 15%
 - More than 18%
 - About 10%

Plant Growth and Development

19. Production of Cucumber has increased manifold in recent years. Application of which of the following phytohormones has resulted in this increased yield as the hormone is known to produce female flowers in the plants:
- Cytokinin
 - ABA
 - Gibberellin
 - Ethylene
20. Which one of the following plants **does not** show plasticity?
- Maize
 - Cotton
 - Coriander
 - Buttercup
21. The gaseous plant growth regulator is used in plants to:
- Kill dicotyledonous weeds in the fields
 - Speed up the malting process
 - Promote root growth and root hair formation to increase the absorption surface
 - Help overcome apical dominance

Sexual Reproduction in Flowering Plants

22. Given below are two statements:

Statement I: Cleistogamous flowers are invariably autogamous

Statement II: Cleistogamy is disadvantageous as there is no chance for cross pollination

In the light of the above statements, choose the correct answer from the options given below.

- Statement I is incorrect but Statement II is correct
- Both Statement I and Statement II are correct
- Both statement I and statement II are incorrect
- Statement I is correct but Statement II is incorrect

23. Identify the **incorrect** statement related to Pollination:

- Moths and butterflies are the most dominant pollinating agents among insects
- Pollination by water is quite rare in flowering plants
- Pollination by wind is more common amongst abiotic pollination
- Flowers produce foul odours to attract flies and beetles to get pollinated

Principles of Inheritance and Variation

24. Given below are two statements:

Statement I: Mendel studied seven pairs of contrasting traits in pea plants and proposed the Laws of Inheritance

Statement II: Seven characters examined by Mendel in his experiment on pea plants were seed shape and colour, flower colour, pod shape and colour, flower position and stem height
In the light of the above statements, choose the correct answer from the options given below.

- Statement I is incorrect but Statement II is correct
- Both Statement I and Statement II are correct
- Both statement I and statement II are incorrect
- Statement I is correct but Statement II is incorrect

25. XO type of sex determination can be found in:

- Monkeys
- Drosophila*
- Birds
- Grasshoppers

Molecular Basis of Inheritance

26. The process of translation of mRNA to proteins **begins** as soon as:

- The tRNA is activated and the larger subunit of ribosome encounters mRNA
- The small subunit of ribosome encounters mRNA
- The larger subunit of ribosome encounters mRNA
- Both the subunits join together to bind with mRNA

27. DNA polymorphism forms the basis of:

- Translation
- Genetic mapping
- DNA finger printing
- Both genetic mapping and DNA finger printing

28. Read the following statements and choose the set of correct statements

- Euchromatin is loosely packed chromatin
- Heterochromatin is transcriptionally active
- Histone octamer is wrapped by negatively charged DNA in nucleosome
- Histones are rich in lysine and arginine
- A typical nucleosome contains 400 bp of DNA helix

Choose the **correct answer** from the options given below.

- A, C and E only
- B, D and E only
- A, C and D only
- B and E only

Biotechnology : Principles and Processes

29. Which one of the following statement is **not true** regarding gel electrophoresis technique?

- Bright orange coloured bands of DNA can be observed in the gel when exposed to UV light.
- The process of extraction of separated DNA strands from gel is called elution.
- The separated DNA fragments are stained by using ethidium bromide.
- The presence of chromogenic substrate gives blue coloured DNA bands on the gel

30. Given below are two statements: one is labelled as Assertion (A) and the other is labelled as Reason (R).

Assertion (A): Polymerase chain reaction is used in DNA amplification

Reason (R): The ampicillin resistant gene is used as a selectable marker to check transformation

In the light of the above statements, choose the correct answer from the options given below.

- (A) is not correct but (R) is correct
- Both (A) and (R) are correct and (R) is the correct explanation of (A)
- Both (A) and (R) are correct but (R) is not the correct explanation of (A)
- (A) is correct but (R) is not correct

Organisms and Populations

31. Which one of the following statements **cannot** be connected to Predation?

- It is necessitated by nature to maintain the ecological balance
- It helps in maintaining species diversity in a community
- It might lead to extinction of a species
- Both the interacting species are negatively impacted

Ecosystem

32. Given below are two statements:

Statement I: Decomposition is a process in which the detritus is degraded into simpler substances by microbes.

Statement II: Decomposition is faster if the detritus is rich in lignin and chitin

In the light of the above statements, choose the correct answer from the options given below.

- Statement I is incorrect but Statement II is correct
- Both Statement I and Statement II are correct
- Both statement I and statement II are incorrect
- Statement I is correct but Statement II is incorrect

Biodiversity and Conservation

33. Which of the following is **not** a method of *ex situ* conservation?
- Cryopreservation
 - In vitro* fertilization
 - National Parks
 - Micropropagation
34. Habitat loss and fragmentation, over exploitation, alien species invasion and co-extinction are causes for:
- Natality
 - Population explosion
 - Competition
 - Biodiversity loss

Environmental Issues

35. The **device** which can remove particulate matter present in the exhaust from a thermal power plant is:
- Catalytic Converter
 - STP
 - Incinerator
 - Electrostatic Precipitator

Botany

Secti on-B

Plant Kingdom

36. Match the plant with the kind of life cycle it exhibits:

List-I		List-II	
(A)	<i>Spirogyra</i>	(i)	Dominant diploid sporophyte vascularplant, with highly reduced male or female gametophyte
(B)	Fern	(ii)	Dominant haploid free-living gametophyte
(C)	<i>Funaria</i>	(iii)	Dominant diploid sporophyte alternating with reduced gametophyte called prothallus
(D)	<i>Cycas</i>	(iv)	Dominant haploid leafy gametophyte alternating with partially dependent multicellular sporophyte

Choose the **correct answer** from the options given below.

- A-ii B-iv C-i D-iii
- A-iv B-i C-ii D-iii
- A-ii B-iii C-iv D-i
- A-iii B-iv C-i D-ii

Cell : The Unit of Life

37. Match List-I with List-II.

List-I		List-II	
(A)	Metacentric chromosome	(i)	Centromere situated close to the end forming one extremely short and one very long arms
(B)	Acrocentric chromosome	(ii)	Centromere at the terminal end
(C)	Sub-metacentric	(iii)	Centromere in the middle forming two equal arms of chromosomes
(D)	Telocentric chromosome	(iv)	Centromere slightly away from the middle forming one shorter arm and one longer arm

Choose the correct answer from the options given below.

- A-i B-ii C-iii D-iv
- A-iii B-i C-iv D-ii
- A-i B-iii C-ii D-iv
- A-ii B-iii C-iv D-i

Biomolecules

38. Read the following statements and choose the set of correct statements

- Lecithin found in the plasma membrane is a glycolipid
- Saturated fatty acids possess one or more c=c bonds
- Gingely oil has lower melting point, hence remains as oil in winter
- Lipids are generally insoluble in water but soluble in some organic solvents
- When fatty acid is esterified with glycerol, monoglycerides are formed

Choose the **correct answer** from the options given below.

- A, B and D only
- A, B and C only
- A, D and E only
- C, D and E only

Transport in Plants

39. Addition of more solutes in a given solution will:

- Not affect the water potential at all
- Raise its water potential
- Lower its water potential
- Make its water potential zero

Photosynthesis in Higher Plants

40. While explaining interspecific interaction of population, (+) sign is assigned for beneficial interaction, (-) sign is assigned for detrimental interaction and (0) for neutral interaction. Which of the following interactions can be assigned (+) for one species and (-) for another species involved in the interaction?

- Competition
- Predation
- Amensalism
- Commensalism

Respiration in Plants

41. What is the role of large bundle sheath cells found around the vascular bundles in C_4 plants?
- To protect the vascular tissue from high light intensity
 - To provide the site for photorespiratory pathway
 - To increase the number of chloroplast for the operation of Calvin cycle
 - To enable the plant to tolerate high temperature

Sexual Reproduction in Flowering Plants

42. Which part of the fruit, labelled in the given figure makes it a false fruit?

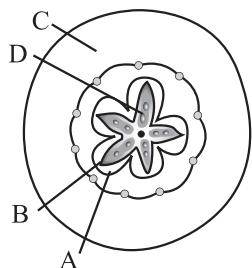

- D → Seed
- A → Mesocarp
- B → Endocarp
- C → Thalamus

Principles of Inheritance and Variation

43. Which of the following occurs due to the presence of autosome linked dominant trait?
- Thalassemia
 - Sickle cell anaemia
 - Myotonic dystrophy
 - Haemophilia
44. Given below are two statements: one is labelled as Assertion (A) and the other is labelled as Reason (R).

Assertion (A): Mendel's law of Independent assortment does not hold good for the genes that are located closely on the same chromosome.

Reason (R): Closely located genes assort independently.

In the light of the above statements, choose the correct answer from the options given below.

- (A) is not correct but (R) is correct
- Both (A) and (R) are correct and (R) is the correct explanation of (A)
- Both (A) and (R) are correct but (R) is not the correct explanation of (A)
- (A) is correct but (R) is not correct

Molecular Basis of Inheritance

45. If a geneticist uses the blind approach for sequencing the whole genome of an organism, followed by assignment of function to different segments, the methodology adopted by him is called as:
- Bioinformatics
 - Sequence annotation
 - Gene mapping
 - Expressed sequence tags
46. The anatomy of springwood shows some peculiar features. Identify the correct set of statements about springwood.
- It is also called as the earlywood
 - In spring season cambium produces xylem elements with narrow vessels
 - It is lighter in colour.
 - The springwood along with autumnwood shows alternate concentric rings forming annual rings
 - It has lower density
- Choose the correct answer from the options given below.
- C, D and E only
 - A, B, D and E only
 - A, C, D and E only
 - A, B and D only

Biotechnology : Principles and Processes

47. In the following palindromic base sequences of DNA, which one can be cut easily by particular restriction enzyme?
- 5' G T A T T C 3' ; 3' C A T A A G 5'
 - 5' G A T A C T 3' ; 3' C T A T G A 5'
 - 5' G A A T T C 3' ; 3' C T T A A G 5'
 - 5' C T C A G T 3' ; 3' G A G T C A 5'

Biotechnology and its Applications

48. Transposons can be used during which one of the following?
- Gene sequencing
 - Polymerase Chain Reaction
 - Gene silencing
 - Autoradiography

Ecosystem

49. Which one of the following will accelerate phosphorus cycle?
- Rain fall and storms
 - Burning of fossil fuels
 - Volcanic activity
 - Weathering of rocks

Environmental Issues

50. The entire fleet of buses in Delhi were converted to CNG from diesel. In reference to this, which one of the following statements is false?
- It can not be adulterated like diesel
 - CNG burns more efficiently than diesel
 - The same diesel engine is used in CNG buses making the cost of conversion low
 - It is cheaper than diesel

Section-A

The Living World

51. In the taxonomic categories which hierarchical arrangement in ascending order is correct in case of animals?
- Kingdom, Order, Phylum, Class, Family, Genus, Species
 - Kingdom, Phylum, Class, Order, Family, Genus, Species
 - Kingdom, Class, Phylum, Family, Order, Genus, Species
 - Kingdom, Order, Class, Phylum, Family, Genus, Species

Animal Kingdom

52. In which of the following animals, digestive tract has additional chambers like crop and gizzard?
- Pavo, Psittacula, Corvus*
 - Corvus, Columba, Chameleon*
 - Bufo, Balaenoptera, Bangarus*
 - Catla, Columba, Crocodilus*
53. Given below are two statements: one is labelled as Assertion (A) and the other is labelled as Reason (R).

Assertion (A): All vertebrates are chordates but all chordates are not vertebrates.

Reason (R): Notochord is replaced by vertebral column in the adult vertebrates

In the light of the above statements, choose the correct answer from the options given below.

- (A) is not correct but (R) is correct
- Both (A) and (R) are correct and (R) is the correct explanation of (A)
- Both (A) and (R) are correct but (R) is not the correct explanation of (A)
- (A) is correct but (R) is not correct

Structural Organisation in Animals

54. Which of the following is present between the adjacent bones of the vertebral column?
- Smooth muscle
 - Intercalated discs
 - Cartilage
 - Areolar tissue
55. Which of the following is **not** a connective tissue?
- Neuroglia
 - Blood
 - Adipose tissue
 - Cartilage
56. Tegmina in cockroach, arises from
- Prothorax and Mesothorax
 - Prothorax
 - Mesothorax
 - Metathorax

Cell : The Unit of Life

57. Given below are two statements:

Statement I: Mycoplasma can pass through less than 1 micron filter size.

Statement II: Mycoplasma are bacteria with cell wall
In the light of the above statements, choose the most appropriate answer from the options given below.

- Statement I is incorrect but Statement II is correct
- Both Statement I and Statement II are correct
- Both statement I and statement II are incorrect
- Statement I is correct but Statement II is incorrect

Cell Cycle and Cell Division

58. Select the **incorrect** statement with reference to mitosis:
- Splitting of centromere occurs at anaphase.
 - All the chromosomes lie at the equator at metaphase.
 - Spindle fibres attach to centromere of chromosomes
 - Chromosomes decondense at telophase.
59. Regarding Meiosis, which of the statements is **incorrect**?
- Four haploid cells are formed at the end of Meiosis-II
 - There are two stages in Meiosis, Meiosis-I and II
 - DNA replication occurs in S phase of Meiosis-II
 - Pairing of homologous chromosomes and recombination occurs in Meiosis-I

Digestion and Absorption

60. Which of the following functions is **not** performed by secretions from salivary glands?
- Digestion of disaccharides
 - Control bacterial population in mouth
 - Digestion of complex carbohydrates
 - Lubrication of oral cavity
61. Given below are two statements:
- Statement I:** Fatty acids and glycerols cannot be absorbed into the blood.
- Statement II:** Specialized lymphatic capillaries called lacteals carry chylomicrons into lymphatic vessels and ultimately into the blood
- In the light of the above statements, choose the most appropriate answer from the options given below.
- Statement I is incorrect but Statement II is correct
 - Both Statement I and Statement II are correct
 - Both statement I and statement II are incorrect
 - Statement I is correct but Statement II is incorrect

Breathing and Exchange of Gases

62. Under normal physiological conditions in human being every 100 ml of oxygenated blood can deliver _____ ml of O_2 to the tissues.
- a. 10 ml b. 2 ml
c. 5 ml d. 4 ml
63. Which of the following is **not** the function of conducting part of respiratory system?
- a. Provides surface for diffusion of O_2 and CO_2
b. It clears inhaled air from foreign particles
c. Inhaled air is humidified
d. Temperature of inhaled air is brought to body temperature

Body Fluids and Circulation

64. Given below are two statements:
- Statement I:** The coagulum is formed of network of threads called thrombins
- Statement II:** Spleen is the graveyard of erythrocytes
- In the light of the above statements, choose the most appropriate answer from the options given below.
- a. Statement I is incorrect but Statement II is correct
b. Both Statement I and Statement II are correct
c. Both statement I and statement II are incorrect
d. Statement I is correct but Statement II is incorrect

Excretory Products and their Elimination

65. Nitrogenous waste is excreted in the form of pellet or paste by
- a. *Pavo* b. *Ornithorhynchus*
c. *Salamandra* d. *Hippocampus*

Locomotion and Movement

66. Which of the following is a correct match for disease and its symptoms?
- a. Muscular dystrophy - An auto immune disorder causing progressive degeneration of skeletal muscle
b. Arthritis - Inflamed joints
c. Tetany - high Ca^{2+} level causing rapid spasms
d. Myasthenia gravis - Genetic disorder resulting in weakening and paralysis of skeletal muscle
67. Given below are two statements: one is labelled as Assertion (A) and the other is labelled as Reason (R).
- Assertion (A):** Osteoporosis is characterised by decreased bone mass and increased chances of fractures
- Reason (R):** Common cause of osteoporosis is increased levels of estrogen
- In the light of the above statements, choose the most appropriate answer from the options given below.
- a. (A) is not correct but (R) is correct
b. Both (A) and (R) are correct and (R) is the correct explanation of (A)
c. Both (A) and (R) are correct but (R) is not the correct explanation of (A)
d. (A) is correct but (R) is not correct

Reproduction in Organisms

68. Identify the asexual reproductive structure associated with *Penicillium*:
- a. Buds b. Zoospores
c. Conidia d. Gemmules

Human Reproduction

69. Which of the following statements are true for spermatogenesis but do not hold true for Oogenesis?
- A. It results in the formation of haploid gametes
B. Differentiation of gamete occurs after the completion of meiosis
C. Meiosis occurs continuously in a mitotically dividing stem cell population
D. It is controlled by the Luteinising hormone (LH) and Follicle Stimulating Hormone (FSH) secreted by the anterior pituitary
E. It is initiated at puberty
- Choose the most appropriate answer from the options given below.
- a. B, C and E only b. C and E only
c. B and C only d. B, D and E only
70. At which stage of life the oogenesis process is initiated?
- a. Adult
b. Puberty
c. Embryonic development stage
d. Birth
71. Given below are two statements:

Statement I: The release of sperms into the seminiferous tubules is called spermiation

Statement II: Spermiogenesis is the process of formation of sperms from spermatogonia

In the light of the above statements, choose the most appropriate answer from the options given below.

- a. Statement I is incorrect but Statement II is correct
b. Both Statement I and Statement II are correct
c. Both statement I and statement II are incorrect
d. Statement I is correct but Statement II is incorrect

Reproductive Health

72. Lippe's loop is a type of contraceptive used as:
- a. Copper releasing IUD b. Cervical barrier
c. Vault barrier d. Non-Medicated IUD

Molecular Basis of Inheritance

73. In an *E.coli* strain *i* gene gets mutated and its product can not bind the inducer molecule. If growth medium is provided with lactose, what will be the outcome?
- a. RNA polymerase will bind the promoter region
b. Only *z* gene will get transcribed
c. *z*, *y*, *a* genes will be transcribed
d. *z*, *y*, *a* genes will not be translated

74. If the length of a DNA molecule is 1.1 metres, what will be the approximate number of base pairs?
- a. 6.6×10^6 bp b. 3.3×10^9 bp
c. 6.6×10^9 bp d. 3.3×10^6 bp

Evolution

75. Natural selection where more individuals acquired specific character value other than the mean character value, leads to:
- a. Random change b. Stabilising change
c. Directional change d. Disruptive change

Human Health and Disease

76. Given below are two statements:
- Statement I:** Autoimmune disorder is a condition where body defense mechanism recognizes its own cells as foreign bodies.
- Statement II:** Rheumatoid arthritis is a condition where body does not attack self cells.
- In the light of the above statements, choose the most appropriate answer from the options given below.
- a. Statement I is incorrect but Statement II is correct
b. Both Statement I and Statement II are correct
c. Both statement I and statement II are incorrect
d. Statement I is correct but Statement II is incorrect
77. In gene therapy of Adenosine Deaminase (ADA) deficiency, the patient requires periodic infusion genetically engineered lymphocytes because:
- a. Genetically engineered lymphocytes are not immortal cells.
b. Retroviral vector is introduced into these lymphocytes.
c. Gene isolated from marrow cells producing ADA is introduced into cells at embryonic stages
d. Lymphocytes from patient's blood are grown in culture, outside the body.

Strategies for Enhancement in Food Production

78. Breeding crops with higher levels of vitamins and minerals or higher proteins and healthier fats is called:
- a. Bio-accumulation b. Bio-magnification
c. Bio-remediation d. Bio-fortification
79. Which of the following statements with respect to Endoplasmic Reticulum is **incorrect**?
- a. SER are the sites for lipid synthesis
b. RER has ribosomes attached to ER
c. SER is devoid of ribosomes
d. In prokaryotes only RER are present

80. A dehydration reaction links two glucose molecules to produce maltose. If the formula for glucose is $C_6H_{12}O_6$ then what is the formula for maltose?
- a. $C_{12}H_{24}O_{11}$ b. $C_{12}H_{20}O_{10}$
c. $C_{12}H_{24}O_{12}$ d. $C_{12}H_{22}O_{11}$

Microbes in Human Welfare

81. Identify the microorganism which is responsible for the production of an immunosuppressive molecule cyclosporin A:
- a. *Streptococcus cerevisiae*
b. *Trichoderma polysporum*
c. *Clostridium butylicum*
d. *Aspergillus niger*

Biodiversity and Conservation

82. In-situ conservation refers to:
- a. Conserve only extinct species
b. Protect and conserve the whole ecosystem
c. Conserve only high risk species
d. Conserve only endangered species

Biotechnology: Principles and Processes

83. Given below are two statements:
- Statement I:** Restriction endonucleases recognise specific sequence to cut DNA known as palindromic nucleotide sequence.
- Statement II:** Restriction endonucleases cut the DNA strand a little away from the centre of the palindromic site
- In the light of the above statements, choose the most appropriate answer from the options given below.
- a. Statement I is incorrect but Statement II is correct
b. Both Statement I and Statement II are correct
c. Both statement I and statement II are incorrect
d. Statement I is correct but Statement II is incorrect

Organisms and Populations

84. If '8' *Drosophila* in a laboratory population of '80' died during a week, the death rate in the population is _____ individuals per *Drosophila* per week.
- a. Zero b. 0.1
c. 10 d. 1.0

Ecosystem

85. Detritivores breakdown detritus into smaller particles. This process is called.
- a. Decomposition b. Catabolism
c. Fragmentation d. Humification

Zoology

Section-B

Biological Classification

86. Which of the following is a correct statement?
- Mycoplasma have DNA, Ribosome and cell wall
 - Cyanobacteria are a group of autotrophic organisms classified under Kingdom Monera
 - Bacteria are exclusively heterotrophic organisms
 - Slime moulds are saprophytic organisms classified under Kingdom Monera.

Structural Organisation in Animals

87. Match List-I with List-II.

List-I		List-II	
(A)	Bronchioles	(i)	Dense Regular Connective Tissue
(B)	Goblet cell	(ii)	Loose Connective Tissue
(C)	Tendons	(iii)	Glandular Tissue
(D)	Adipose Tissue	(iv)	Ciliated Epithelium

Choose the correct answer from the options given below.

- A-iii B-iv C-ii D-i
- A-iv B-iii C-i D-ii
- A-i B-ii C-iii D-iv
- A-ii B-i C-iv D-iii

Biomolecules

88. Match List-I with List-II.

List-I (Biological Molecules)		List-II (Biological function)	
(A)	Glycogen	(i)	Hormone
(B)	Globulin	(ii)	Biocatalyst
(C)	Steroids	(iii)	Antibody
(D)	Thrombin	(iv)	Storage product

Choose the correct answer from the options given below.

- A-iv B-iii C-i D-ii
- A-iii B-ii C-iv D-i
- A-iv B-ii C-i D-iii
- A-ii B-iv C-iii D-i

Body Fluids and Circulation

89. Which one of the following statements is correct?
- Increased ventricular pressure causes closing of the semilunar valves
 - The atrio-ventricular node (AVN) generates an action potential to stimulate atrial contraction
 - The tricuspid and the bicuspid valves open due to the pressure exerted by the simultaneous contraction of the atria
 - Blood moves freely from atrium to the ventricle during joint diastole.

Neural Control and Coordination

90. Select the incorrect statement regarding synapses:
- Impulse transmission across a chemical synapse is always faster than that across an electrical synapse.
 - The membranes of presynaptic and postsynaptic neurons are in close proximity in an electrical synapse.
 - Electrical current can flow directly from one neuron into the other across the electrical synapse.
 - Chemical synapses use neurotransmitters

Chemical Coordination and Integration

91. Which of the following are not the effects of Parathyroid hormone?

- Stimulates the process of bone resorption
- Decrease Ca^{2+} level in blood
- Reabsorption of Ca^{2+} by renal tubules
- Decrease the absorption of Ca^{2+} from digested food
- Increases metabolism of carbohydrates

Choose the most appropriate answer from the options given below:

- B and C only
- A and C only
- B, D and E only
- A and E only

Reproductive Health

92. Match List-I with List-II with respect to methods of Contraception and their respective actions.

List-I		List-II	
(A)	Diaphragms	(i)	Inhibit ovulation and Implantation
(B)	Contraceptive Pills	(ii)	Increase phagocytosis of sperm within Uterus
(C)	Intra Uterine Devices	(iii)	Absence of Menstrual cycle and ovulation following parturition
(D)	Lactational Amenorrhoea	(iv)	They cover the cervix blocking the entry of sperms

Choose the correct answer from the options given below.

- A-iii B-ii C-i D-iv
- A-iv B-i C-iii D-ii
- A-iv B-i C-ii D-iii
- A-ii B-iv C-i D-iii

Principles of Inheritance and Variation

93. If a colour blind female marries a man whose mother was also colour blind, what are the chances of her progeny having colour blindness?
- 100%
 - 25%
 - 50%
 - 75%

Molecules Basis of Inheritance

94. Ten *E.coli* with ^{15}N - dsDNA are incubated in medium containing ^{14}N nucleotide. After 60 minutes, how many *E.coli* cells will have DNA totally free from ^{15}N ?
- 80 cells
 - 20 cells
 - 40 cells
 - 60 cells
95. The recombination frequency between the genes a & c is 5%, b & c is 15%, b & d is 9%, a & b is 20%, c & d is 24% and a & d is 29%. What will be the sequence of these genes on a linear chromosome? [OS]
- a, c, b, d
 - a, d, b, c
 - d, b, a, c
 - a, b, c, d

Evolution

96. Which of the following statements is **not** true?
- Flippers of penguins and dolphins are a pair of homologous organs
 - Analogous structures are a result of convergent evolution
 - Sweet potato and potato is an example of analogy
 - Homology indicates common ancestry

Human Health and Disease

97. Select the **incorrect** statement with respect to acquired immunity.
- Acquired immunity is non-specific type of defense present at the time of birth
 - Primary response is produced when our body encounters a pathogen for the first time.
 - Anamnestic response is elicited on subsequent encounters with the same pathogen.
 - Anamnestic response is due to memory of first encounter.

Biotechnology: Principles and Processes

98. Which of the following is **not** a desirable feature of a cloning vector?
- Presence of two or more recognition sites
 - Presence of origin of replication
 - Presence of a marker gene
 - Presence of single restriction enzyme site

Biotechnology and its Applications

99. Statements related to human Insulin are given below. Which statement(s) is/are correct about genetically engineered Insulin?
- Pro-hormone insulin contain extra stretch of C-peptide
 - A-peptide and B-peptide chains of insulin were produced separately in *E.coli*, extracted and combined by creating disulphide bond between them.
 - Insulin used for treating Diabetes was extracted from Cattles and Pigs.
 - Pro-hormone Insulin needs to be processed for converting into a mature and functional hormone.
 - Some patients develop allergic reactions to the foreign insulin.

Choose the most appropriate answer from the options given below.

- C, D and E only
- A, B and D only
- B only
- C and D only

Environmental Issues

100. Given below are two statements:

Statement I: In a scrubber the exhaust from the thermal plant is passed through the electric wires to charge the dust particles.

Statement II: Particulate matter (PM 2.5) can not be removed by scrubber but can be removed by an electrostatic precipitator.

In the light of the above statements, choose the most appropriate answer from the options given below.

- Statement I is incorrect but Statement II is correct
- Both Statement I and Statement II are correct
- Both statement I and statement II are incorrect
- Statement I is correct but Statement II is incorrect

Answer Key

1	2	3	4	5	6	7	8	9	10	11	12	13	14	15	16	17
c	d	c	d	c	none	b	d	d	d	d	c	c	c	b	c	d
18	19	20	21	22	23	24	25	26	27	28	29	30	31	32	33	34
a	d	a	c	b	a	b	d	b	d	c	d	c	d	d	c	d
35	36	37	38	39	40	41	42	43	44	45	46	47	48	49	50	51
d	c	b	d	c	b	c	d	c	d	b	c	c	c	d	c	b
52	53	54	55	56	57	58	59	60	61	62	63	64	65	66	67	68
a	b	c	a	c	d	c	c	a	b	c	a	a	a	b	d	c
69	70	71	72	73	74	75	76	77	78	79	80	81	82	83	84	85
a	c	c	d	d	b	c	d	a	d	d	d	b	b	b	b	c
86	87	88	89	90	91	92	93	94	95	96	97	98	99	100		
b	b	a	d	a	c	c	a	d	a	a	a	a	c	c		

CHEMISTRY

NEET

Solved Paper

2022

Section-A

Some Basic Concepts of Chemistry

1. What mass of 95% pure CaCO_3 will be required to neutralise 50 mL of 0.5 M HCl solution according to the following reaction?



[Calculate upto second place of decimal point]

- a. 9.50 g b. 1.25 g
c. 1.32 g d. 3.66 g

Structure of Atom

2. Identify the **incorrect** statements from the following.
- The shapes of d_{xy} , d_{yz} , and d_{zx} orbitals are similar to each other; and $dx^2 - y^2$ and d_{z^2} are similar to each other.
 - All the five 5d orbitals are different in size when compared to the respective 4d orbitals.
 - All the five 4d orbitals have shapes similar to the respective 3d orbitals.
 - In an atom, all the five 3d orbitals are equal in energy in free state.

Classification of Elements & Periodicity in Properties

3. The IUPAC name of an element with atomic number 119 is.
- ununotium
 - ununennium
 - unnilemium
 - unununium

Chemical Bonding and Molecular Structure

4. Amongst the following which one will have **maximum** 'lone pair-lone pair' electron repulsions?
- XeF_2
 - ClF_3
 - IF_5
 - SF_4

5. Which amongst the following is **incorrect** statement

- O_2^+ ion is diamagnetic.
- The bond orders of O_2^+ , O_2 , O_2^- and O_2^{2-} are 2.5, 2, 1.5 and 1, respectively
- C_2 molecule has four electrons in its two degenerate π molecular orbitals.
- H_2^+ ion has one electron.

Thermodynamics

6. Which of the following p-V curve represents **maximum work done**?

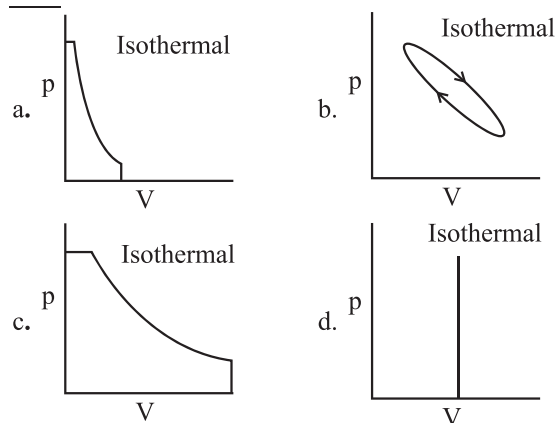

Equilibrium

7. The pH of the solution containing 50 mL each of 0.10 M sodium acetate and 0.01 M acetic acid is [Given pK_a of $\text{CH}_3\text{COOH} = 4.57$]
- 2.57
 - 5.57
 - 3.57
 - 4.57

Redox Reactions

8. Identify the **incorrect** statement from the following
- Lithium is the strongest reducing agent among the alkali metals.
 - Alkali metals react with water to form their hydroxides.

- c. The oxidation number of K in KO_2 is +4.
 d. Ionisation enthalpy of alkali metals decreases from top to bottom in the group.
9. At 298 K, the standard electrode potentials of Cu^{2+}/Cu , Zn^{2+}/Zn , Fe^{2+}/Fe and Ag^+/Ag are 0.34 V, -0.76 V, -0.44 V and 0.80 V, respectively.

On the basis of standard electrode potential, predict which of the following reaction can not occur?

- a. $2\text{CuSO}_4(\text{aq}) + 2\text{Ag}(\text{s}) \rightarrow 2\text{Cu}(\text{s}) + \text{Ag}_2\text{SO}_4(\text{aq})$
 b. $\text{CuSO}_4(\text{aq}) + \text{Zn}(\text{s}) \rightarrow \text{ZnSO}_4(\text{aq}) + \text{Cu}(\text{s})$
 c. $\text{CuSO}_4(\text{aq}) + \text{Fe}(\text{s}) \rightarrow \text{FeSO}_4(\text{aq}) + \text{Cu}(\text{s})$
 d. $\text{FeSO}_4(\text{aq}) + \text{Zn}(\text{s}) \rightarrow \text{ZnSO}_4(\text{aq}) + \text{Fe}(\text{s})$

Hydrogen

10. Match List-I with List-II

List-I (Hydrides)	List-II (Nature)
(a) MgH_2	(i) Electron precise
(b) GeH_4	(ii) Electron deficient
(c) B_2H_6	(iii) Electron rich
(d) HF	(iv) Ionic

Choose the correct answer from the options given below:

- a. (a)-(ii), (b)-(iii), (c)-(iv), (d)-(i)
 b. (a)-(iv), (b)-(i), (c)-(ii), (d)-(iii)
 c. (a)-(iii), (b)-(i), (c)-(ii), (d)-(iv)
 d. (a)-(i), (b)-(ii), (c)-(iv), (d)-(iii)

The s-Block Elements

11. Match List I with List II.

List-I	List-II
(a) Li	(i) absorbent for carbon dioxide
(b) Na	(ii) electrochemical cells
(c) KOH	(iii) coolant in fast breeder reactors
(d) Cs	(iv) photoelectric cell

Choose the **correct answer** from the options given below:

- a. (a)-(ii), (b)-(iii), (c)-(i), (d)-(iv)
 b. (a)-(iv), (b)-(i), (c)-(iii), (d)-(ii)
 c. (a)-(iii), (b)-(iv), (c)-(ii), (d)-(i)
 d. (a)-(i), (b)-(iii), (c)-(iv), (d)-(ii)

The p-Block Elements

12. Choose the **correct** statement:

- a. Both diamond and graphite are used as dry lubricants.
 b. Diamond and graphite have two dimensional network
 c. Diamond is covalent and graphite is ionic
 d. Diamond is sp^3 hybridised and graphite is sp^2 hybridized.

13. Which of the following statement is **not correct** about diborane?

- a. Both the Boron atoms are sp^2 hybridised.
 b. There are two 3-centre-2-electron bonds.
 c. The four terminal B-H bonds are two centre two electron bonds
 d. The four terminal Hydrogen atoms and the two Boron atoms lie in one plane.

Organic Chemistry: Some Basic Principles and Techniques

14. The Kjeldahl's method for the estimation of nitrogen **can be used** to estimate the amount of nitrogen in which one of the following compounds?

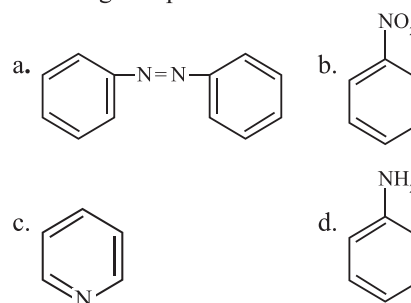

Hydrocarbons

15. Which compound amongst the following is **not an aromatic** compound?

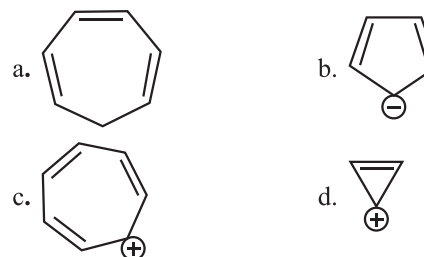

16. Which of the following is **suitable** to synthesize chlorobenzene?

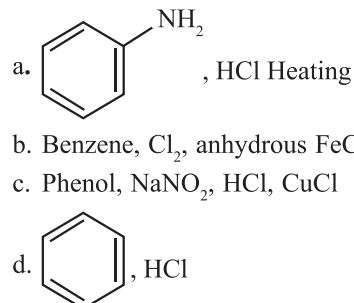

The Solid State

17. Given below are two statements: one is labelled as **Assertion (A)** and the other is labelled as **Reason (R)**.

Assertion (A) : In a particular point defect, an ionic solid is electrically neutral, even if few of its cations are missing from its unit cells.

Reason (R) : In an ionic solid, Frenkel defect arises due to dislocation of cation from its lattice site to interstitial site, maintaining overall electrical neutrality.

In the light of the above statements, choose the **most appropriate** answer from the options given below:

- (A) is not correct but (R) is correct
- Both (A) and (R) are correct and (R) is the correct explanation of (A)
- Both (A) and (R) are correct but (R) is not the correct explanation of (A)
- (A) is correct but (R) is not correct

Solutions

18. In one molal solution that contains 0.5 mole of a solute, there is
- 1000 g of solvent
 - 500 mL of solvent
 - 500 g of solvent
 - 100 mL of solvent
19. Which one is **not** correct mathematical equation for Dalton's Law of partial pressure? Here p = total pressure of gaseous mixture
- $p_i = x_i p_i^\circ$, where x_i = mole fraction of i^{th} gas in gaseous mixture
 p_i° = pressure of i^{th} gas in pure state
 - $p = p_1 + p_2 + p_3$
 - $p = n_1 \frac{RT}{V} + n_2 \frac{RT}{V} + n_3 \frac{RT}{V}$
 - $p_i = x_i p$, where p_i = partial pressure of i^{th} gas
 x_i = mole fraction of i^{th} gas in gaseous mixture

Electrochemistry

20. Given below are half cell reactions:

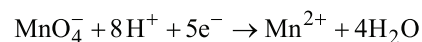

$$E_{\text{Mn}^{2+}/\text{MnO}_4^-}^\circ = -1.510\text{V}$$

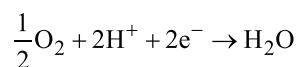

$$E_{\text{O}_2/\text{H}_2\text{O}} = +1.223\text{V}$$

Will the permanganate ion, MnO_4^- **liberate** O_2 from water in the presence of an acid?

- No because $E_{\text{cell}}^\circ = -2.733\text{V}$
- Yes, because $E_{\text{cell}}^\circ = +0.287\text{V}$
- No, because $E_{\text{cell}}^\circ = -0.287\text{V}$
- Yes, because $E_{\text{cell}}^\circ = +2.733\text{V}$

Chemical Kinetics

21. The given graph is a representation of kinetics of a reaction.

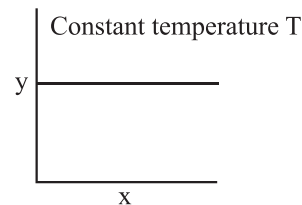

The y and x axes for zero and first order reactions, respectively are

- zero order (y = rate and x = concentration), first order (y = rate and $x = t_{1/2}$)
- zero order (y = concentration and x = time), first order ($y = t_{1/2}$ and $x = c$ concentration)
- zero order (y = concentration and x = time), first order (y = rate constant and x = concentration)
- zero order (y = rate and x = concentration), first order ($y = t_{1/2}$ and $x = concentration$)

Surface Chemistry

22. Given below are two statements:

Statement I : In the coagulation of negative sol, the flocculating power of the three given ions is in the order- $\text{Al}^{3+} > \text{Ba}^{2+} > \text{Na}^+$

Statement II : In the coagulation of positive sol, the flocculating power of the three salts is in the order- $\text{NaCl} > \text{Na}_2\text{SO}_4 > \text{Na}_3\text{PO}_4$

In the light of the above statements, choose the **most appropriate** answer from the options given below:

- Statement I** is incorrect but **Statement II** is correct
- Both **Statement I** and **Statement II** are correct.
- Both **Statement I** and **Statement II** are incorrect.
- Statement I** is correct but **Statement II** is incorrect.

The p-Block Elements (Group 15 to 18)

23. Given below are two statements: one is labelled as **Assertion (A)** : and the other is labelled as **Reason (R)**

Assertion (A) : ICl is **more** reactive than I_2 .

Reason (R) : I-Cl bond is **weaker** than I-I bond

In the light of the above statements, choose the **most appropriate** answer from the options given below:

- (A) is not correct but (R) is correct.
- Both (A) and (R) are correct and (R) is the correct explanation of (A).
- Both (A) and (R) are correct but (R) is not the correct explanation of (A).
- (A) is correct but (R) is not correct.

24. Given below are two statements:

Statement I : The boiling points of the following hydrides of group 16 elements increases in the order- $\text{H}_2\text{O} < \text{H}_2\text{S} < \text{H}_2\text{Se} < \text{H}_2\text{Te}$.

Statement II : The boiling points of these hydrides increase with increase in molar mass.

In the light of the above statements, choose the **most appropriate** answer from the options given below:

- Statements I** is incorrect but **Statements II** is correct.
- Both **Statements I** and **Statements II** are correct
- Both **Statements I** and **Statements II** are incorrect
- Statements I** is correct but **Statements II** is incorrect

The d-and f-Block Elements

25. Gadolinium has a **low** value of third ionisation enthalpy because of
- high basic character
 - small size
 - high exchange enthalpy
 - high electronegativity

Coordination Compounds

26. The IUPAC name of the complex-
[Ag(H₂O)₂][Ag(CN)₂] is:
- diaquasilver(I) dicyanidoargentate(I)
 - dicyanidosilver(II) diaquaargentate(II)
 - diaquasilver(II) dicyanidoargentate(II)
 - dicyanidosilver(I) diaquaargentate(I)

Haloalkanes and Haloarenes

27. The **incorrect** statement regarding chirality is:
- A racemic mixture shows zero optical rotation.
 - S_N1 reaction yields 1 : 1 mixture of both enantiomers.
 - The product obtained by S_N2 reaction of haloalkane having chirality at the reactive site shows inversion of configuration.
 - Enantiomers are superimposable mirror images on each other.

Alcohols, Phenols and Ethers

28. Given below are two statements:

Statement I: The acidic strength of monosubstituted nitrophenol is higher than phenol because of electron withdrawing nitro group.

Statement II: o-nitrophenol, m-nitrophenol and p-nitrophenol will have same acidic strength as they have one nitro group attached to the phenolic ring.

In the light of the above statements, choose the **most appropriate** answer from the options given below:

- Statement I** is incorrect but **Statement II** is correct.
- Both **Statement I** and **Statement II** are correct.
- Both **Statement I** and **Statement II** are incorrect.
- Statement I** is correct but **Statement II** is incorrect.

Aldehydes, Ketones and Carboxylic Acids

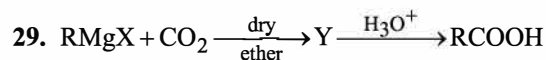

What is **Y** in the above reaction?

- (RCOO)₂Mg
- RCOO⁻Mg⁺X
- R₃CO⁻Mg⁺X
- RCOO⁻X⁺

30. Given below are two statements:

Statements: I The boiling points of aldehydes and ketones are higher than hydrocarbons of comparable molecular mass because of weak molecular association in aldehydes and ketones due to dipole - dipole interactions.

Statements: II : The boiling points of aldehydes and ketones are lower than the alcohols of similar molecular mass due to the absence of H-bonding.

In the light of the above statements, choose the **most appropriate** answer from the options given below

- Statements I** is incorrect but **Statements II** is correct.
- Both **Statements I** and **Statement II** are correct.
- Both **Statements I** and **Statements II** are incorrect.
- Statements I** is correct but **Statements II** is incorrect.

31. Match List-I with List-II.

List-I (Products formed)	List-II (Reaction of carbonyl compound with)
(a) Cyanohydrin	(i) NH ₂ OH
(b) Acetal	(ii) RNH ₂
(c) Schiff's base	(iii) alcohol
(d) Oxime	(iv) HCN

Choose the correct answer from the options given below:

- (a)-(iv), (b)-(iii), (c)-(ii), (d)-(i)
- (a)-(iii), (b)-(iv), (c)-(ii), (d)-(i)
- (a)-(ii), (b)-(iii), (c)-(iv), (d)-(i)
- (a)-(i), (b)-(iii), (c)-(ii), (d)-(iv)

Amines

32. Given below are two statements:

Statements I : Primary aliphatic amines react with HNO₂ to give unstable diazonium salts.

Statements II : Primary aromatic amines react with HNO₂ to form diazonium salts which are stable even above 300 K.

In the light of the above Statements, choose the **most appropriate** answer from the options given below:

- Statements I** is incorrect but **Statements II** is correct.
- Both **Statements I** and **Statements II** are correct
- Both **Statements I** and **Statements II** are incorrect.
- Statements I** is correct but **Statement II** is incorrect.

Biomolecules

33. The **incorrect** statement regarding enzymes is
- Enzymes are very specific for a particular reaction and substrate
 - Enzymes are biocatalysts
 - Like chemical catalysts enzymes reduce the activation energy of bio process.
 - Enzymes are polysaccharides.

Polymers

34. Which statement regarding polymers is **not correct**?
- Thermosetting polymers are reusable.
 - Elastomers have polymer chains held together by weak intermolecular forces
 - Fibers possess high tensile strength.
 - Thermoplastic polymers are capable of repeatedly softening and hardening on heating and cooling respectively

Chemistry in Everyday Life

35. Match List- I with List II.

List (Drug class)	List-II (Drug molecule)
(a) Antacids	(i) Salvarsan
(b) Antihistamines	(ii) Morphine
(c) Analgesics	(iii) Cimetidine
(d) Antimicrobials	(iv) Seldane

Choose the **correct answer** from the options given below:

- (a)-(iv), (b)-(iii), (c)-(i), (d)-(ii)
- (a)-(iii), (b)-(ii), (c)-(iv), (d)-(i)
- (a)-(iii), (b)-(iv), (c)-(ii), (d)-(i)
- (a)-(i), (b)-(iv), (c)-(ii), (d)-(iii)

Section-B**Structure of Atom**

36. If radius of second Bohr orbit of the He^+ ion is 105.8 pm, what is the **radius** of third Bohr orbit of Li^{2+} ion?
- 158.7 Å
 - 158.7 pm
 - 15.87 pm
 - 1.587 pm

States of Matter

37. A 10.0 L flask contains 64 g of oxygen at 27° C. (Assume O_2 gas is behaving ideally). The **pressure** inside the flask in bar is
- (Given $R = 0.0831 \text{ L bar K}^{-1} \text{ mol}^{-1}$)
- 4.9
 - 2.5
 - 498.6
 - 49.8

Equilibrium

38. $3\text{O}_2(\text{g}) \rightleftharpoons 2\text{O}_3(\text{g})$ for the given reaction at 298 K, K_c is found to be 3.0×10^{-59} . If the concentration of O_2 at equilibrium is 0.040 M then **concentration of O_3** in M is
- 1.2×10^{21}
 - 4.38×10^{-32}
 - 1.9×10^{-63}
 - 2.4×10^{31}

Organic Chemistry: Some Basic Principles and Techniques

39. The correct **IUPAC name** of the following compound is:

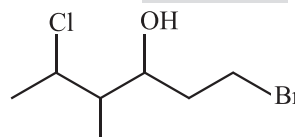

- 6-bromo-4-methyl-2-chlorohexan-4-ol
- 1-bromo-5-chloro-4-methylhexan-3-ol
- 6-bromo-2-chloro-4-methylhexan-4-ol
- 1-bromo-4-methyl-5-chlorohexan-3-ol

Hydrocarbons

40. Compound X on reaction with O_3 followed by $\text{Zn}/\text{H}_2\text{O}$ gives formaldehyde and 2-methyl propanal as products. The **compound X** is:
- Pent-2-ene
 - 3-Methylbut-1-ene
 - 2-Methylbut-1-ene
 - 2-Methylbut-2-ene

Environmental Chemistry

41. The **pollution** due to oxides of sulphur gets **enhanced** due to the presence of:
- particulate matter
 - ozone
 - hydrocarbons
 - hydrogen peroxide

Choose the **most appropriate** answer from the options given below:

- a. A, C, D only b. A, D only
c. A, B, D only d. B, C, D only

The Solid State

42. Copper crystallises in fcc unit cell with cell edge length of 3.608×10^{-8} cm. The density of copper is 8.92 g cm^{-3} . Calculate the atomic mass of copper.
- a. 65 u b. 63.1 u
c. 31.55 u d. 60

Electrochemistry

43. Find the emf of the cell in which the following reaction takes place at 298 K
- $$\text{Ni(s)} + 2\text{Ag}^+ (0.001 \text{ M}) \rightarrow \text{Ni}^{2+} (0.001 \text{ M}) + 2\text{Ag(s)}$$
- (Given that $E^\circ_{\text{cell}} = 10.5 \text{ V}$, $\frac{2.303 RT}{F} = 0.059$ at 298 K)
- a. 1.05 V b. 1.0385 V
c. 1.385 V d. 0.9615 V

Chemical Kinetics

44. For a first order reaction $A \rightarrow \text{Products}$, initial concentration of A is 0.1 M, which becomes 0.001 M after 5 minutes. Rate constant for the reaction in min^{-1} is
- a. 0.2303 b. 1.3818
c. 0.9212 d. 0.4606

General Principles and Processes of Isolation of Elements

45. Match List-I with List-II.

List-I (Ores)	List-II (Composition)
A. Haematite	(i) Fe_3O_4
B. Magnetite	(ii) ZnCO_3
C. Calamine	(iii) Fe_2O_3
D. Kaolinite	(iv) $[\text{Al}_2(\text{OH})_4\text{Si}_2\text{O}_5]$

Choose the **correct answer** from the options given below:

- a. (A)-(i), (B)-(iii), (C)-(ii), (D)-(iv)
b. (A)-(i), (B)-(ii), (C)-(iii), (D)-(iv)
c. (A)-(iii), (B)-(i), (C)-(ii), (D)-(iv)
d. (A)-(iii), (B)-(i), (C)-(iv), (D)-(ii)

The d- and f-Block Elements

46. In the neutral or faintly alkaline medium, KMnO_4 oxidises iodide into iodate. The change in oxidation state of manganese in this reaction is from
- a. +6 to +5 b. +7 to +4
c. +6 to +4 d. +7 to +3

Coordination Compounds

47. The order of energy absorbed which is responsible for the color of complexes
- A. $[\text{Ni}(\text{H}_2\text{O})_2(\text{en})_2]^{2+}$
B. $[\text{Ni}(\text{H}_2\text{O})_4(\text{en})]^{2+}$ and
C. $[\text{Ni}(\text{en})_3]^{2+}$
is
- a. $B > A > C$ b. $A > B > C$
c. $C > B > A$ d. $C > A > B$

Alcohols, Phenols and Ethers

48. Given below are two statements:

Statement I: In Lucas test, primary, secondary and tertiary alcohols are distinguished on the basis of their reactivity with conc. $\text{HCl} + \text{ZnCl}_2$, known as Lucas Reagent.

Statement II: Primary alcohols are most reactive and immediately produce turbidity at room temperature on reaction with Lucas Reagent.

In the light of the above statements, choose the **most appropriate** answer from the options given below:

- a. Statement I is incorrect but Statement II is correct.
b. Both Statement I and Statement II are correct.
c. Both Statement I and Statement II are incorrect.
d. Statement I is correct but Statement II is incorrect.

Aldehydes, Ketones and Carboxylic Acids

49. Which one of the following is **not formed** when acetone reacts with 2-pentanone in the presence of dilute NaOH followed by heating?

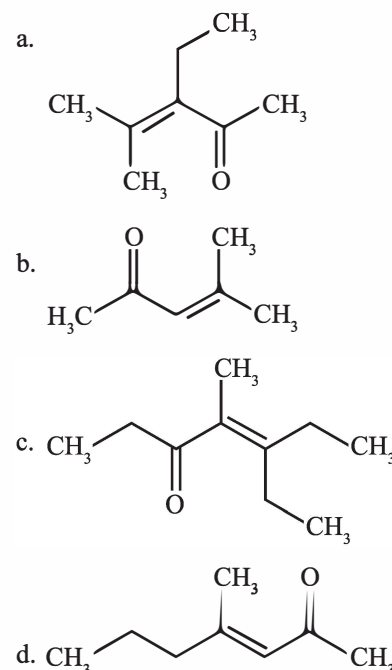

Amines

50. The product formed from the following reaction sequence is

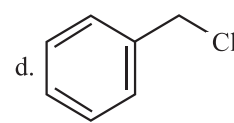
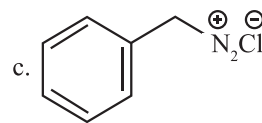
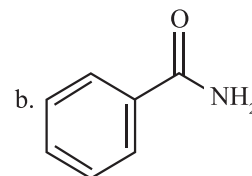
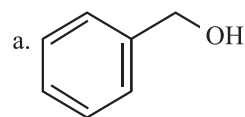
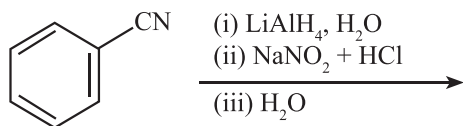
**Answer Key**

1	2	3	4	5	6	7	8	9	10	11	12	13	14	15	16	17
c	a	b	a	a	c	b	c	a	b	a	d	a	d	a	b	c
18	19	20	21	22	23	24	25	26	27	28	29	30	31	32	33	34
c	a	b	d	d	b	c	c	a	d	d	b	b	a	d	d	a
35	36	37	38	39	40	41	42	43	44	45	46	47	48	49	50	
c	b	a	b	b	b	c	b	None	c	c	b	d	d	c	a	

PHYSICS

SECTION-A

Units & Measurements

- Plane angle and solid angle have :
 - Both units and dimension
 - Units but no dimensions
 - Dimensions but no units
 - No units and no dimensions
- The dimension $[MLT^{-2}A^{-2}]$ belong to the :
 - electric permittivity
 - magnetic flux
 - self inductance
 - magnetic permeability

Motion in a Straight Line

- The ratio of the distance traveled by a freely falling body in the 1st, 2nd, 3rd and 4th second :
 - 1 : 1 : 1 : 1
 - 1 : 2 : 3 : 4
 - 1 : 4 : 9 : 16
 - 1 : 3 : 5 : 7
- The displacement time graphs of two moving particle make angles of 30° and 45° with the x-axis as shown in the figure. The ratio of their respective velocity is :

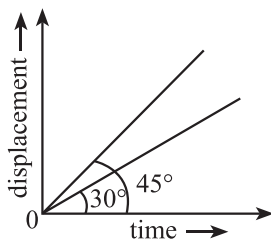

- $1 : \sqrt{3}$
- $\sqrt{3} : 1$
- 1 : 1
- 1 : 2

Laws of Motion

- A shell of mass m is at rest initially. It explodes into three fragments having mass in the ratio 2 : 2 : 1. If the fragments having equal mass fly off along mutually perpendicular directions with speed v , the speed of the third (lighter) fragment is:
 - $3\sqrt{2}v$
 - v
 - $\sqrt{2}v$
 - $2\sqrt{2}v$

Work, Energy and Power

- An electric lift with a maximum load of 2000 kg (lift + passengers) is moving up with a constant speed of 1.5ms^{-1} . The frictional force opposing the motion is 3000 N. The minimum power delivered by the motor to the lift in watts is : ($g = 10\text{ms}^{-2}$)
 - 23500
 - 23000
 - 20000
 - 34500
- The energy that will be ideally radiated by a 100 kW transmitter in 1 hour is :
 - $1 \times 10^5\text{ J}$
 - $36 \times 10^7\text{ J}$
 - $36 \times 10^4\text{ J}$
 - $36 \times 10^5\text{ J}$

System of Particles and Rotational Motion

- The angular speed of a fly wheel moving with uniform angular acceleration changes from 1200 rpm to 3120 rpm in 16 seconds. The angular acceleration in rad/s^2 is :
 - 104p
 - 2p
 - 4p
 - 12p
- The ratio of the radius of gyration of a thin uniform disc about an axis passing through its centre and normal to its plane to the radius of gyration of the disc about its diameter is:
 - $1 : \sqrt{2}$
 - 2 : 1
 - $\sqrt{2} : 1$
 - 4 : 1
- Two objects of mass 10 kg and 20 kg respectively are connected to the two ends of a rigid rod of length 10 m with negligible mass. The distance of the centre of mass of the system from the 10 kg mass is :
 - 5m
 - $\frac{10}{3}\text{m}$
 - $\frac{20}{3}\text{m}$
 - 10 m

Gravitation

11. A body of mass 60 g experiences a **gravitational force** of 3.0 N, when placed at a particular point. The magnitude of the **gravitational field intensity** at that point is :
- 180 N/kg
 - 0.05 N/kg
 - 50 N/kg
 - 20 N/kg

Mechanical Properties of Fluids

12. A spherical ball is dropped in a long column of a highly viscous liquid. The curve in the graph shown which represents the **speed of the ball** (v) as a function of time (t) is:

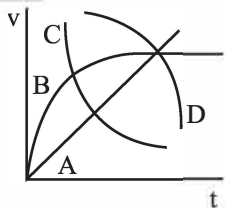

- D
 - A
 - B
 - C
13. If a soap bubble **expands**, the **pressure** inside the bubble :
- is equal to the atmospheric pressure
 - decreases
 - increases
 - remains the same

Thermodynamics

14. An ideal gas undergoes four different processes from the same initial state as shown in the figure below. Those processes are adiabatic, isothermal, isobaric and isochoric. The curve which represents the **adiabatic process** among 1, 2, 3 and 4 is :

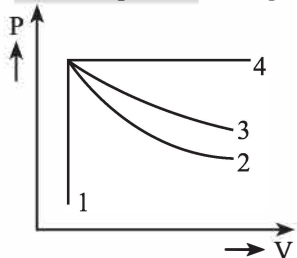

- 4
 - 1
 - 2
 - 3
15. If the initial tension on a stretched string is **doubled**, then the ratio of the initial and final speed of a transverse wave along the string is :
- 1 : 2
 - 1 : 1
 - $\sqrt{2} : 1$
 - 1 : $\sqrt{2}$

Electrostatic Potential and Capacitance

16. Two **hollow conducting sphere** of radii R_1 and R_2 ($R_1 \gg R_2$) have **equal charges**. The potential would be:
- dependent on the material property of the sphere
 - more on bigger sphere
 - more on smaller sphere
 - equal on both the sphere

17. The angle between the electric lines of force and the equipotential surface is :
- 180°
 - 0°
 - 45°
 - 90°

Current Electricity

18. As the temperature **increases**, the **electrical resistance** :
- decrease for conductors but increases for semiconductors
 - increases for both conductors and semiconductors
 - decreases for both conductors and semiconductors
 - increases for conductors but decreases for semiconductors
19. A copper wire of length 10 m and radius $(10^{-2}/\sqrt{\pi})$ m has electrical resistance of 10 Ω . The **current density** in the wire for an **electric field** strength of 10 V/m is :
- 10^5 A/m²
 - 10^4 A/m²
 - 10^6 A/m²
 - 10^{-5} A/m²
20. Two resistors of resistance, 100 Ω and 200 Ω are connected **in parallel** in an electrical circuit. The ratio of the **thermal energy** developed in 100 Ω to that in 200 Ω in a given time is :
- 4 : 1
 - 1 : 2
 - 2 : 1
 - 1 : 4

Moving Charges and Magnetism

21. Given below are two statements :

Statement I : Biot-Savart's law gives us the expression for the magnetic field strength of an infinitesimal current element ($Id\vec{\ell}$,) of the current carrying conductor only.

Statement II : Biot-Savart's law is analogous to Coulomb's inverse square law of charge q , with the former being related to the field produced by a scalar source, $Id\vec{\ell}$, while the latter being produced by a vector source, q .

In light of above statements choose the **most appropriate answer** from the options given below

- Statement I is incorrect and statement II is correct
 - Both Statement I and Statement II are correct
 - Both statement I and Statement II are incorrect
 - Statement I is correct and Statement II is incorrect.
22. A long solenoid of radius 1 mm has **100 turns per mm**. If 1A current flows in the solenoid, the **magnetic field strength** at the centre of the solenoid is :
- 6.28×10^{-4} T
 - 6.28×10^{-2} T
 - 12.56×10^{-2} T
 - 12.56×10^{-4} T

Electromagnetic Induction

23. A square loop of side 1 m and resistance 1 Ω is placed in a magnetic field of 0.5T. If the plane of loop of **perpendicular** to the direction of a magnetic field, the **magnetic flux** through the loop is :
- zero weber
 - 2 weber
 - 0.5 weber
 - 1 weber

Alternating Current

24. The peak voltage of the ac source is equal to
- $\frac{1}{\sqrt{2}}$ times the rms value of the source
 - the value of voltage supplied to the circuit
 - the rms value of the ac source
 - $\sqrt{2}$ times the rms value of the ac source

Electromagnetic Waves

25. When light propagates through a material medium of relative permittivity ϵ_r and relative permeability μ_r , the velocity of light, v is given by : (c - velocity of light in vacuum)

$$\begin{array}{ll} \text{a. } v = \frac{c}{\sqrt{\epsilon_r \mu_r}} & \text{b. } v = c \\ \text{c. } v = \sqrt{\frac{\mu_r}{\epsilon_r}} & \text{d. } v = \sqrt{\frac{\epsilon_r}{\mu_r}} \end{array}$$

26. Match List-I with List-II

List-I	List-II
(Electromagnetic waves)	(Wavelength)
a. AM radio waves	(i) 10^{-10} m
b. Microwaves	(ii) 10^2 m
c. Infra-red radiations	(iii) 10^{-2} m
d. X-rays	(iv) 10^{-4} m

Choose the correct answer from the options given below:

- (a)-(ii), (b)-(iii), (c)-(iv), (d)-(i)
- (a)-(iv), (b)-(iii), (c)-(ii), (d)-(i)
- (a)-(iii), (b)-(ii), (c)-(i), (d)-(iv)
- (a)-(iii), (b)-(iv), (c)-(ii), (d)-(i)

Ray Optics and Optical Instruments

27. A biconvex lens has radii of curvature, **20 cm each**. If the refractive index of the material of the lens is 1.5, the power of the lens is :
- Infinity
 - +2D
 - +20D
 - +5D
28. A light ray falls on a glass surface of refractive index $\sqrt{3}$, at an angle 60° . The angle between the refracted and reflected rays would be :
- 120°
 - 30°
 - 60°
 - 90°

Wave Optics

29. In a Young's double slit experiment, a student observes 8 fringes in a certain segment of screen when a monochromatic light of 600 nm wavelength is used. If the wavelength of light is changed to 400 nm, then the number of fringes he would observe in the same region of the screen is
- 12
 - 6
 - 8
 - 9

Dual Nature of Radiation and Matter

30. The graph which shows the variation of the de Broglie wavelength (λ) of a particle and its associated momentum (p) is :

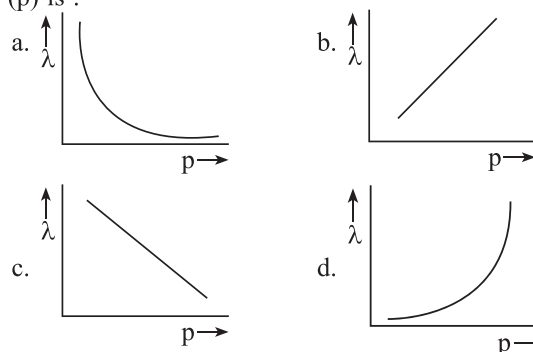

31. When two monochromatic light of frequency, ν and $\nu/2$ are incident on a photoelectric metal, their stopping potential becomes $V_s/2$ and V_s respectively. The threshold frequency for this metal is :
- $\frac{3}{2}\nu$
 - 2ν
 - 3ν
 - $\frac{2}{3}\nu$

Atoms

32. Let T_1 and T_2 be the energy of an electron in the first and second excited states of hydrogen atom, respectively. According to the Bohr's model of an atom, the ratio $T_1 : T_2$ is :
- 9 : 4
 - 1 : 4
 - 4 : 1
 - 4 : 9

Nuclei

33. In the given nuclear reaction, the element X is :

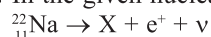

- ${}_{12}^{22}\text{Mg}$
- ${}_{11}^{22}\text{Na}$
- ${}_{10}^{22}\text{Ne}$
- ${}_{10}^{22}\text{Ne}$

Semiconductor Electronics

34. In half wave rectification, if the input frequency is 60 Hz, then the output frequency would be:
- 120 Hz
 - 0
 - 30 Hz
 - 60 Hz

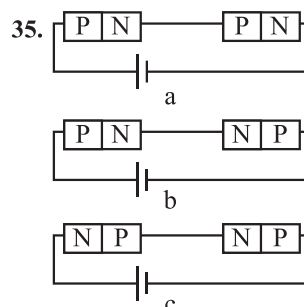

In the given circuits (a), (b) and (c), the potential drop across the two p-n junctions are equal in :

- Both circuits (a) and (c)
- Circuit (a) only
- Circuit (b) only
- Circuit (c) only

SECTION-B

Units & Measurements

36. The **area** of a rectangular field (in m^2) of length 55.3 m and breadth 25 m after rounding off the value for correct **significant digits** is :
- a. 14×10^2 b. 138×10^1
 c. 1382 d. 1382.5

Motion in a Plane

37. A ball is projected with a velocity, 10 ms^{-1} , at an angle of 60° with the **vertical direction**. Its **speed** at the highest point of its trajectory will be :
- a. 10 ms^{-1} b. Zero
 c. $5\sqrt{3} \text{ ms}^{-1}$ d. 5 ms^{-1}

Gravitation

38. Match List-I and List-II

List-I	List-II
a. Gravitational constant (G)	(i) $[\text{L}^2\text{T}^{-2}]$
b. Gravitational potential Energy	(ii) $[\text{M}^{-1}\text{L}^3\text{T}^{-2}]$
c. Gravitational potential	(iii) $[\text{LT}^{-2}]$
d. Gravitational Intensity	(iv) $[\text{ML}^2\text{T}^{-2}]$

Choose the correct answer from the options given below:

- a. (a)-(iv), (b)-(ii), (c)-(i), (d)-(iii)
 b. (a)-(ii), (b)-(i), (c)-(iv), (d)-(iii)
 c. (a)-(ii), (b)-(iv), (c)-(i), (d)-(iii)
 d. (a)-(ii), (b)-(iv), (c)-(iii), (d)-(i)

Mechanical Properties of Solids

39. Given below are two statements : One is labelled as Assertion (A) and the other is labelled as Reason (R)

Assertion (A) : The stretching of a spring is determined by the shear modulus of the material of the spring

Reason (R) : A coil spring of copper has more tensile strength than a steel spring of same dimensions.

In the light of the above statements, choose the **most appropriate answer** from the options given below :

- a. (A) is false but (R) is true
 b. Both (A) and (R) are true and (R) is the correct explanation of (A)
 c. Both (A) and (R) are true and (R) is not the correct explanation of (A)
 d. (A) is true but (R) is false

Kinetic Theory

40. The **volume occupied** by the molecules contained in 4.5 kg water at **STP**, if the intermolecular forces **vanish away** is :
- a. 5.6 m^3 b. $5.6 \times 10^6 \text{ m}^3$
 c. $5.6 \times 10^3 \text{ m}^3$ d. $5.6 \times 10^{-3} \text{ m}^3$

Oscillations

41. Two pendulums of length 121 cm and 100 cm start vibrating **in phase**. At some instant, the two are at their means position in the **same phase**. The **minimum number of vibrations** of the shorter pendulum after which the two are again in phase at the means position is :
- a. 8 b. 11
 c. 9 d. 10

Electric Charges and Fields

42. Two point charges $-q$ and $+q$ are placed at a distance of L , as shown in the figure



The magnitude of **electric field intensity** at a distance R ($R \gg L$) varies as

- a. $\frac{1}{R^6}$ b. $\frac{1}{R^2}$
 c. $\frac{1}{R^3}$ d. $\frac{1}{R^4}$

Electrostatic Potential and Capacitance

43. A capacitor of capacitance $C = 900 \text{ pF}$ is charged fully by 100 V battery B as shown in figure (a). Then it is disconnected from the battery and connected to another **uncharged capacitor** of capacitance $C = 900 \text{ pF}$ as shown in figure (b). The **electrostatic energy** stored by the system (b) is

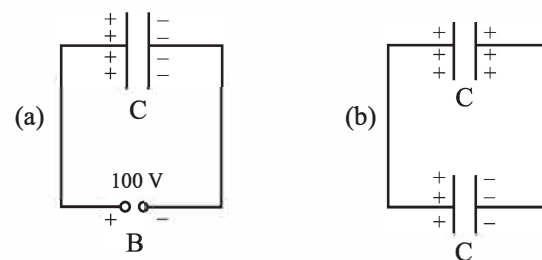

- a. $1.5 \times 10^{-6} \text{ J}$ b. $4.5 \times 10^{-6} \text{ J}$
 c. $3.25 \times 10^{-6} \text{ J}$ d. $2.25 \times 10^{-6} \text{ J}$

Current Electricity

44. A wheatstone bridge is used to determine the value of unknown resistance X by adjusting the variable resistance Y as shown in the figure. For the most precise measurement of X , the resistances P and Q :

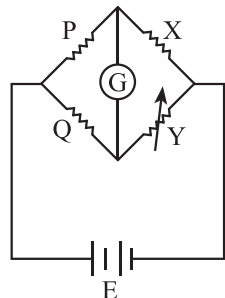

- do not play any significant role
- should be approximately equal to $2X$
- should be approximately equal and are small
- should be very large and unequal

Moving Charges and Magnetism

45. From Ampere's circuital law for a long straight wire of circular cross section carrying a steady current, the variation of magnetic field in the inside and outside region of the wire is :
- a linearly decreasing function of distance upto the boundary of the wire and then a linearly increasing one for the outside region.
 - uniform and remains constant for both the regions.
 - a linearly increasing function of distance upto the boundary of the wire and then decreasing outside region.
 - a linearly increasing function of distance r upto the boundary of the wire $1/r$ dependence for the outside region.

Electromagnetic Induction

46. A big circular coil of 100 turns and average radius 10 m is rotating about its horizontal diameter at 2 rad s^{-1} . If the vertical component of earth's magnetic field at that place is $2 \times 10^{-5} \text{ T}$ and electrical resistance of the coil is 12.56Ω , then the maximum induced current in the coil will be :
- 2A
 - 0.25 A
 - 1.5 A
 - 1 A

Alternating Current

47. A series LCR circuit with inductance 10 H, capacitance $10 \mu\text{F}$, resistance 50Ω is connected to an ac source of voltage, $V = 200 \sin(100t)$ volt. If resonant frequency of the LCR circuit is ν_0 and the frequency of the ac source is ν , then :
- $\nu = 100\text{Hz}$; $\nu_0 = \frac{100}{\pi} \text{Hz}$
 - $\nu_0 = \nu = 50 \text{ Hz}$
 - $\nu_0 = \nu = \frac{50}{\pi} \text{Hz}$
 - $\nu_0 = \frac{50}{\pi} \text{Hz}$, $\nu = 50 \text{ Hz}$

Ray Optics and Optical Instruments

48. Two transparent media A and B are separated by a plane boundary. The speed of light in those media are $1.5 \times 10^8 \text{ m/s}$ and $2.0 \times 10^8 \text{ m/s}$, respectively. The critical angle for a ray of light for these two media is :
- $\tan^{-1}(0.750)$
 - $\sin^{-1}(0.500)$
 - $\sin^{-1}(0.750)$
 - $\tan^{-1}(0.500)$

Nuclei

49. A nucleus of mass number 189 splits into two nuclei having mass number 125 and 64. The ratio of radius of two daughter nuclei respectively is :
- 25 : 16
 - 1 : 1
 - 4 : 5
 - 5 : 4

Semiconductor Electronics

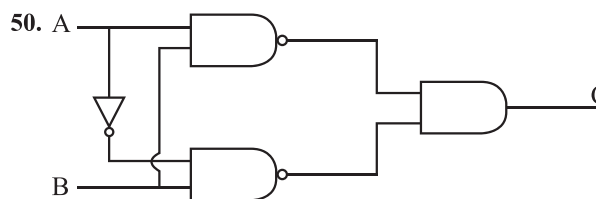

The truth table for the given logic circuit is :

a.	A	B	C
	0	0	0
	0	1	1
	1	0	0
	1	1	1

b.	A	B	C
	0	0	0
	0	1	1
	1	0	1
	1	1	0

c.	A	B	C
	0	0	1
	0	1	0
	1	0	0
	1	1	1

d.	A	B	C
	0	0	1
	0	1	0
	1	0	1
	1	1	0

Answer Key

1	2	3	4	5	6	7	8	9	10	11	12	13	14	15	16	17
b	d	d	a	d	d	b	c	c	c	c	c	b	c	d	c	d
18	19	20	21	22	23	24	25	26	27	28	29	30	31	32	33	34
d	a	c	d	c	c	d	a	a	d	d	a	a	none	a	d	d
35	36	37	38	39	40	41	42	43	44	45	46	47	48	49	50	
a	a	c	c	d	a	b	c	d	c	d	d	c	c	d	d	